



NZ Starling National Championships

17-21 April 2025

The Organising Authority is
Howick Sailing Club, Howick Beach, Auckland

SAILING INSTRUCTIONS

The notation [NP] in a rule means that a boat may not protest another boat for breaking that rule. This changes RRS 60.1. The notation [DP] is defined in the RRS introduction.

1 RULES

- 1.1 The event is governed by the rules as defined in *The Racing Rules of Sailing*.
- 1.2 The Yachting New Zealand Safety Regulations Part 1 shall apply.
- 1.3 The Starling Class rules including 18.1 and 18.2 will apply

18.1 RRS 42.3 is changed by adding: The Race Committee may signal in accordance with RRS Appendix P5 that pumping, rocking and ooching are permitted after the starting signal, except when the boat's proper course is close-hauled or above. This changes rules 42.2(a), 42.2(b) and 42.2(c).

18.2 The Starling Class recommends that race committees apply Rule 18.1 in winds of 15 knots and above, measured at deck level on a race committee boat at the windward mark

- 1.4 Appendix P shall apply as amended in the Sailing Instructions.
- 1.5 Appendix T, Arbitration will apply.

2 CHANGES TO SAILING INSTRUCTIONS

- 2.1 Any change to the sailing instructions will be posted before 0900 on the day it will take effect, except that any change to the schedule of races will be posted by 2000 on the day before it will take effect.

3 COMMUNICATION WITH COMPETITORS

- 3.1 Notices to competitors will be posted on the official notice board located in front of the Howick Sailing Club clubhouse. Notices will be replicated on-line at



Howicksailingclub.co.nz.

3.2 The Race Office is located at the Howick Coastguard buildings.

4 CODE OF CONDUCT

4.1 [DP] Competitors and support persons shall comply with reasonable requests from race officials.

4.2 [DP] Competitors and support persons shall place advertising provided by the Organising Authority with care, seamanship, in accordance with any instructions for its use and without interfering with its functionality.

5 SIGNALS MADE ASHORE

5.1 Signals made ashore will be displayed on a flag pole adjacent to the Waterwise kiosk building (west side of HSC Clubhouse).

5.2 When flag AP is displayed ashore, '1 minute' is replaced with 'not less than 30 minutes' in race signal, AP.

5.3 A boat shall not leave the shore until flag D is displayed with one sound. The warning signal will not be made before the schedule time or less than 30 minutes after flag D is displayed. [NP]

6 FORMAT OF RACING

Development Fleet

6.1 The format, start, type of races for each race in the Development Fleet Series will be described in the daily briefing (refer SI 7.1). This may change RRS 26.

Open Fleet

6.2 All boats in the Open fleet will race and be scored as one fleet unless split into a Qualifying Series and Final Series as defined in NoR 7.3.

6.3 If a Qualifying Series and Finals Series is sailed, the format of racing will follow **SI Addendum A – Qualifying Series and Finals Series.**

7 SCHEDULE OF RACES

7.1 Briefings:

Development Fleet

(a) There will be a daily briefing for the Development Fleet each day of racing at 1000hrs in front of the Howick Sailing Club clubhouse. All Development Fleet sailors should attend as it may contain information regarding the format of the day's racing. A de-brief may be held after racing each day.

Open Fleet

(b) The briefing is scheduled immediately after the Event Welcome at 0900hrs on Friday 18th April in front of the Howick Sailing Club clubhouse.

7.2 Race schedule:

Open Fleet:

Day / Date	1st Warning signal	Race Schedule
Friday 18 April	1100	3 races
Saturday 19 April	1030	3 races
Sunday 20 April	1030	3 races
Monday 21 April	1000	3 races

Starling Development Fleet:

Day / Date	1st Warning signal	Race Schedule
Friday 18 April	1130	Up to 3 races
Saturday 19 April	1130	Up to 3 races
Sunday 20 April	1130	Up to 3 races
Monday 21 April	1100	Up to 2 races

7.3 One extra race per day may be sailed, provided that no fleet becomes more than one race ahead of schedule and the change is made according to SI 2.1.

7.4 To alert boats that a race or sequence of races will begin soon, the orange starting line flag will be displayed with one sound at least five minutes before a warning signal is made.

7.5 On the last scheduled day of racing no warning signal will be made after 1430hrs.

8 CLASS FLAGS

Development Fleet

8.1 The class flag will be the Starling Class insignia (red star) on a GREEN background.

Open Fleet

8.2 (a) If the Open Fleet is sailed as one fleet, the class flag will be the Starling Class insignia (red star) on a WHITE background.

(b) If the Open Fleet has a Qualifying Series and a Final Series:

(i) the class flags will be Yellow and Blue for the Qualifying Fleets, and

(ii) the class flags will be Yellow for the Gold Fleet and Blue for the Silver Fleet for any Finals Series.

9 RACING AREA

9.1 The racing area is located in the Tamaki Strait directly off Howick Beach, east of Musick Point and west of Beachlands.

10 COURSES

Development Fleet

- 10.1 The Courses to be sailed, the start, the finish and any rounding marks will be described in the daily briefing (refer SI 6.1 and SI 7.1).
- 10.2 Course may be laid courses or “adventure” / “destination” courses.

Open Fleet

- 10.3 The diagram(s) in **SI Addendum B – Course Diagrams** show(s) the course(s), including the approximate angles between legs, the order in which marks are to be passed, and the side on which each mark is to be left

11 MARKS

- 11.1 Mark descriptions are provided in **SI Addendum B – Course Diagrams**.

12 THE START

- 12.1 The starting line is between a staff displaying an orange flag on the signal vessel at the starboard end and the course side of the port-end starting mark.
- 12.2 A small orange teardrop buoy may be streamed directly astern of the Committee Boat at the start line. The buoy and the connecting line are to be considered a part of the Committee Boat. See definition of a “Mark” (*RRS Definitions - Mark*).
- 12.3 If a Qualifying Series and Final Series is sailed:
i) For the Qualifying Series, the Yellow fleet will start first, followed by the Blue fleet.
ii) For the Final Series, the Gold fleet will start first, followed by the Silver fleet
- 12.4 [DP][NP] Boats whose warning signal has not been made shall avoid the starting area during the starting sequence for other races.
- 12.5 A boat that does not start within 4 minutes after her starting signal will be scored Did Not Start without a hearing. This changes RRS A5.1 and A5.2.

13 CHANGE OF THE NEXT LEG OF THE COURSE

- 13.1 To change the next leg of the course, the Race Committee will lay a new mark (or move the finishing line) and remove the original mark as soon as practicable. When in a subsequent change a new mark is replaced, it will be replaced by an original mark.

14 THE FINISH

- 14.1 The finishing line will be between a staff displaying a blue flag on the finishing mark at the starboard end and the course side of the port-end finishing mark.

15 PENALTY SYSTEM

- 15.1 Appendix P will apply as changed by SI 15.2 and 15.3.
- 15.2 RRS Appendix P2.2 and Appendix P2.3 will not apply and RRS Appendix P2.1 is changed so that it will apply to Appendix P penalty.
- 15.3 If a boat is penalised under Appendix P2.1 after she has finished, she shall be given a scoring penalty of 10%, scored in accordance with RRS 44.3(c), without a hearing.

16 TIME LIMITS AND TARGET TIMES

16.1 The Race Time Limit, Target Time and the Finishing Window are shown in the table below:

Class/Fleet	Target Time	Race Time Limit	Finishing Window
Open Fleet	45 minutes	70 minutes	20 minutes
Development Fleet	30 minutes	50 minutes	20 minutes

- 16.2 For the **Development Fleet**, Race Time Limit, Target Time and the Finishing Window maybe altered at the daily briefing (refer SI 6.1 and SI 7.1).
- 16.3 Boats failing to finish within the Finish Window after the first boat starts, sails the course and finishes within the race time limit will be scored Did Not Finish without a hearing. This changes RRS 35, A5.1 and A5.2
- 16.4 Failure to meet the Target Time will not be grounds for redress. This changes RRS 61.4(b)(1).

17 HEARING REQUESTS

- 17.1 The protest time limit is 60 minutes after the last boat in that fleet finishes the last race of the day or the Race Committee signals no more racing today, whichever is later. The time will be posted on the official notice board.
- 17.2 Hearing request forms are available from the Race Office which is located in the Howick Coastguard buildings.
- 17.3 Notices will be posted no later than 30 minutes after the protest time limit to inform competitors of hearings in which they are parties or named as witnesses. Hearings will be held in the protest room, located at Race Office.
- 17.4 A list of boats that have been penalized for breaking RRS 42 under Appendix P will be posted.
- 17.5 Breaches of Sailing Instructions 12.4 (Avoiding starting area), 18 (Safety Regulations), 21 (Support teams), will not be grounds for protest by a boat. This changes RRS 60.1.
- 17.6 Immediately after finishing, a boat intending to protest shall, in addition to the requirements of RRS 60.2(a)(1), inform the Race Committee at the finishing line of her



intention to protest and the identity of the boat(s) protested against. The protesting boat must receive an acknowledgement from the Race Committee. This changes RRS 60.

18 SAFETY REGULATIONS [DP][NP]

18.1 Boats not leaving the shore for a scheduled race shall promptly notify the race office.

18.2 Check-out and check-in ashore

- a) At registration, competitors will be issued with an “**ID Tag**” for the **Check-out / Check-in Ashore process**
- b) On each day of racing, competitors shall individually check-out before racing by personally placing their ID Tag on the Check-out board located in front of the Howick Coastguard Buildings at the main designated launch/beach ramp.
- c) Competitors shall individually check-in immediately on returning to shore after racing by personally placing their ID Tag on the Check-in board located in front of the Howick Coastguard Buildings at the main designated launch/beach ramp.

18.3 A boat that retires from a race shall notify the Race Committee at the first reasonable opportunity.

19 REPLACEMENT OF CREW OR EQUIPMENT

19.1 Substitution of competitors is not allowed.

19.2 [DP] Substitution of damaged or lost equipment is not allowed unless authorised in writing by the Race Committee. Requests for substitution shall be made to the committee at the first reasonable opportunity, which may be after the race.

20 EQUIPMENT AND MEASUREMENT CHECKS

20.1 A boat or equipment may be inspected at any time for compliance with the class rules, notice of race and sailing instructions

20.2 [DP] When instructed by a race official on the water, a boat shall proceed to a designated area for inspection.

21 SUPPORT TEAMS [DP] [NP]

21.1 Except when requested to participate in rescue operations, team leaders, coaches, and other support persons shall stay outside areas where boats are racing and are restricted to a 5 knot speed limit, from the time of the preparatory signal for the first start of a sequence of starts until all boats have finished or the Race Committee signals a postponement or abandonment of all races. The areas the boats are racing in is defined as the area inside the course and within 100 metres of any mark, lay line, starting line, finishing line or any area where any boat that is racing, is sailing or may sail.

21.2 All support vessels shall always have a kill-cord attached to the driver while the engine is running, unless prior written exemption has been provided by the Organising Authority.

21.3 Attention is drawn to the relevant local council bylaws regarding the wearing of lifejackets/PDFs and other restrictions.

<https://at.govt.nz/media/1986434/navigation-bylaw.pdf>

21.4 When flag V (with a long sound signal) is displayed on a committee boat, all support vessels are requested to remain afloat and assist all sailors.

22 TRASH DISPOSAL

22.1 Trash may be placed aboard official (or support person) vessels.

23 PRIZES

23.1 **Open Fleet - Under 19, unless stipulated otherwise.**

John Peet Trophy shall be awarded to the highest placed competitor in the overall open fleet results and they shall be awarded the title *Starling National Champion*.

Kohi Cup shall be awarded to the second highest placed competitor in the Open Fleet.

Murrays Bay Cup shall be awarded to the third highest placed competitor in the Open Fleet.

Alan Sayer Trophy shall be awarded to the highest placed female competitor in the Open Fleet.

John Binsley Trophy shall be awarded to the second highest placed female competitor in the Open Fleet.

Chris Timms Trophy shall be awarded to the highest placed under 16 year old in the overall Open Fleet.

The Harken Trophy shall be awarded to the youngest skipper in the first 10 places overall in the Open Fleet.

The Cooke Trophy shall be awarded to the leading competitor at the end of the Qualifying Series. If there is no Qualifying Series this trophy shall be awarded to the boat leading the series after the middle race of the series, or if there are two middle races then after the later of these two races.

The Howick Cup shall be awarded to the winner of the Silver division of the Open Fleet. If there is no Qualifying/Final Series, this trophy shall be awarded to the boat finishing nearest to the middle of the fleet. If two boats are the middle boats it shall be awarded to the lower of these boats.

The Queen Charlotte Trophy shall be awarded to the most improved skipper in the Open Fleet throughout the championship.

The Graeme Leonard Hays Shield shall be awarded to any skipper, who in the opinion of the host club, showed exceptional courage and effort during the event.

23.2 **Open Fleet Over 19**

The Des Townson Trophy shall be awarded to the highest placed competitor over 19 in the Open Fleet.

23.3 Development Fleet

The Development Fleet Trophy shall be awarded to the highest placed competitor under 19 in the Development Fleet.

23.4 As stipulated in the Starling Class Rules, the age date for prizes is the 31 January 2025.

24 RISK STATEMENT

24.1 RRS 3 states: 'The responsibility for a boat's decision to participate in a race or to continue to race is hers alone.' By participating in this event each competitor agrees and acknowledges that sailing is a potentially dangerous activity with inherent risks. These risks include strong winds and rough seas, sudden changes in weather, failure of equipment, boat handling errors, poor seamanship by other boats, loss of balance on an unstable platform and fatigue resulting in increased risk of injury. **Inherent in the sport of sailing is the risk of permanent, catastrophic injury or death by drowning, trauma, hypothermia or other causes.**

25 INSURANCE

25.1 Each participating boat shall be insured with valid third-party liability insurance with a minimum cover of \$1,000,000 per incident or the equivalent. Certificate of insurance may be requested at registration.

Addendum A: Qualifying Series and Final Series

1 INTRODUCTION

- 1.1 If entries in the Open Fleet exceed 90 boats, the Open Fleet Series will consist of a Qualifying Series and a Final Series.

2 QUALIFYING SERIES

- 2.1 For the Qualifying Series, boats will be assigned to 2 fleets (“Yellow” and “Blue”) of, as near as possible, equal size. Initial fleet assignments will be made by a Seeding Committee appointed by the Organising Authority.
- 2.2 Initial fleet assignments will be posted on the Official Notice Board no later than 0900hrs on Friday 18 April. Boats shall display the appropriate colour ribbon for the fleet that they have been assigned, either Yellow or Blue.
- 2.3 The ribbon shall be attached to the boat’s mast or top batten. Ribbons and instructions for attachment will be available at the time of registration or from the Race Office.
- 2.4 Boats will be reassigned to fleets after each day’s racing, except if on the first day only one race is completed. If all fleets have completed the same number of races, boats will be reassigned on the basis of their ranking in the series. If all fleets have not completed the same number of races, their series scores for reassignment will be calculated for those races, numbered in order of completion, completed by all fleets.
- 2.5 For two fleets, reassignments will be made as follows:

Ranking in series	Fleet ranking
1 st	Yellow
2 nd	Blue
3 rd	Blue
4 th	Yellow
5 th	Yellow
6 th	Blue
and so on	

- 2.6 Assignments will be based on the series ranking available at 2000hrs that day regardless of protests or requests for redress not yet decided.
- 2.7 New assignments will be posted as a Notice to Competitors no later than 0830hrs on the day they take effect.
- 2.8 If all fleets have not completed the same number of races by the end of a day, the fleet with fewer races will continue racing on the following day until all fleets have completed the same number of races. All boats will thereafter race in new fleets for

the remainder of the day.

- 2.9 The Qualifying Series will be deemed to be finished at the end of the second day, unless less than 3 races have been completed by the end of racing on Saturday 19 April (Race Day 2), when the finals series will follow on Sunday 20 April.
- 2.10 If fewer than 3 races have been sailed by the end of racing on Saturday 19 April, the Qualifying Series shall continue on Sunday 20 April and a Final Series shall be held on the final day Monday 21 April.
- 2.11 If fewer than 3 races have been sailed by the end of racing on Sunday 20 April, the Qualifying Series shall continue on Monday 21 April and there will be no Final Series.
- 2.12 If at the end of the Qualifying Series, a qualifying fleet has more race scores than the other, any extra races will be discounted so that all boats in the Qualifying Series have the same number of race scores.

3 FINALS SERIES

- 3.1 Boats will be assigned to Final Series fleets on the basis of their ranking in the Qualifying Series. Boats with the best Qualifying Series ranking will race all Final Series races in the Gold Fleet; boats with the next best Qualifying Series ranks will race in the Silver Fleet.
- 3.2 The Final Series will comprise of a Gold Fleet and Silver Fleet.
- 3.3 The Final Series fleets will be, as nearly as possible, of equal size but so that the Silver Fleet is not larger than the Gold Fleet.
- 3.4 Any recalculation of Qualifying Series ranking after boats have been assigned to Final Series fleets will not affect the assignments except that a redress decision may promote a boat to a higher fleet.
- 3.5 Different Final Series fleets need not have completed the same number of Final Series races.

4 SCORING

- 4.1 A boat that did not start, did not finish, retired after finishing or was disqualified will be scored points for the finishing place one more than the Maximum Number as per Addendum A 4.3. This changes RRS A4.2, Low Point System.
- 4.2 Where a scoring penalty under either RRS 30.2, RRS 44.3(c) or Appendix T, Arbitration, the number of places will be the whole number (rounding 0.5 upward) nearest to 10%, 20% or 30% as the case may be, of one more than the maximum number as per Addendum A 4.3.

- 4.3 When a Qualifying/Final Series is sailed, the Maximum Number for Addendum A 4.1 and Addendum A 4.2 is:
- a) For races in the Qualifying Series, the largest number of boats assigned to any of the qualifying fleets.
 - b) For races in the Final Series, the number of boats in her fleet.
- 4.4 During the Qualifying Series, only races that have been completed by all fleets will be included in the series scoring.
- 4.5 When a Qualifying/Final Series is sailed, one race score will be discarded when calculating the division into Final Series fleets.
- 4.6 Boats will be scored according to their finishing positions in their fleet in the Qualifying and Final Series. A boat assigned to the Gold Fleet shall be scored in the final championship rankings higher than any boat in the Silver Fleet



Addendum B: Course Diagrams

Course Illustration - Trapezoid with beat to finish - separate finish

IW

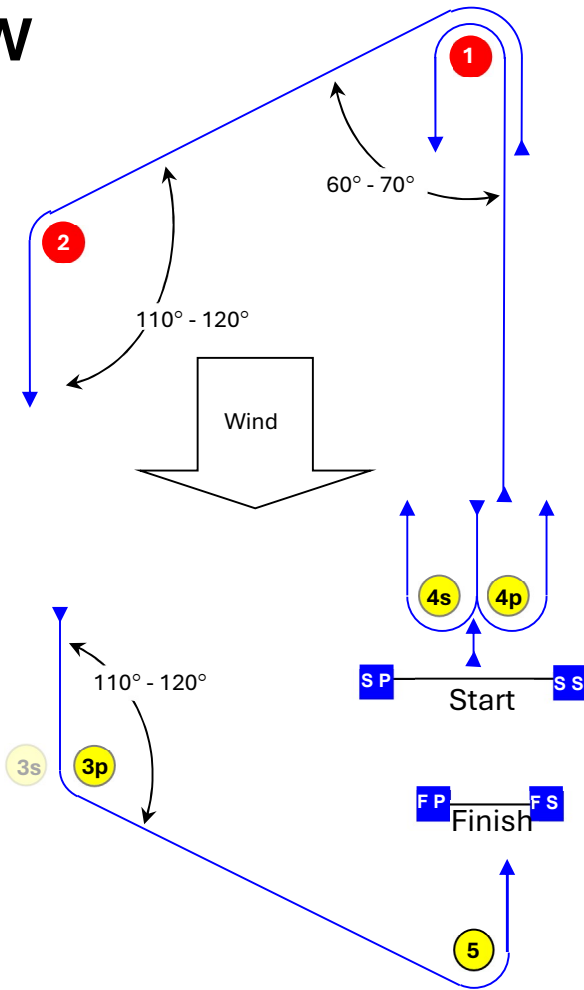

Course: Inner Trapezoid with beat to finish

Signal	Mark Rounding Order
IW1	Start - 1 - 2 - 3p - 5 - Finish
IW2	Start - 1 - 4s/4p - 1 - 2 - 3p - 5 - Finish

OW

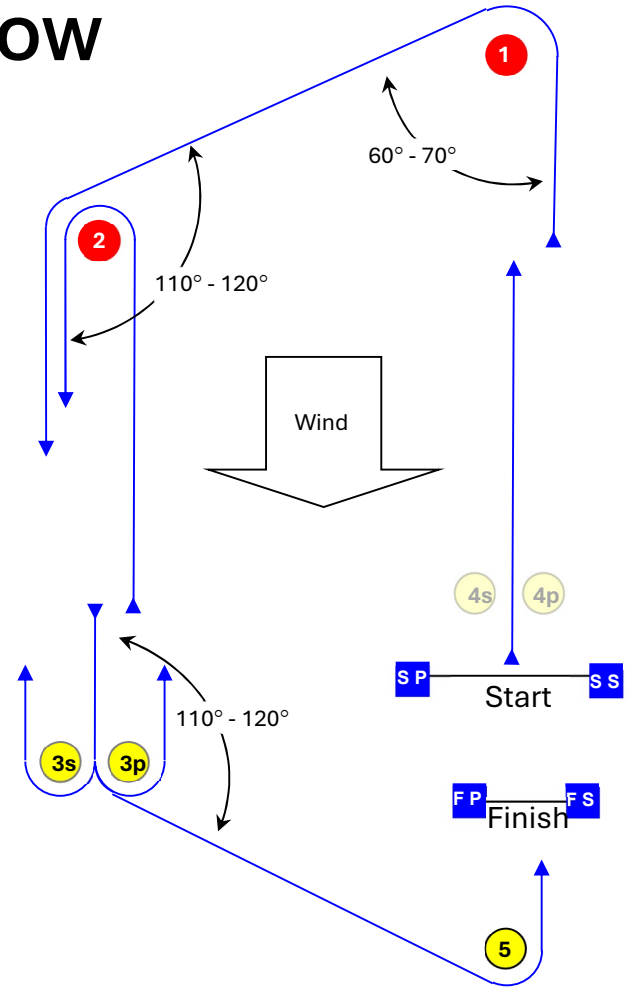

Course: Outer Trapezoid with beat to finish

Signal	Mark Rounding Order
OW1	Start - 1 - 2 - 3p - 5 - Finish
OW2	Start - 1 - 2 - 3s/3p - 2 - 3p - 5 - Finish

Mark	Description
1 2	Red YAMAHA cylinder buoys
3s 3p	Yellow cylinder buoys
4s 4p	Yellow cylinder buoys
5	Yellow conical buoy
SS Starting mark starboard end	Committee boat
SP Starting mark port end	Orange teardrop buoy with an ORANGE flag
FS Finishing mark starboard end	Committee boat
FP Finishing mark port end	Orange teardrop buoy with a BLUE flag
○ Replacement mark	Orange conical buoy

Course Illustrations – Windward Leeward with a windward finish

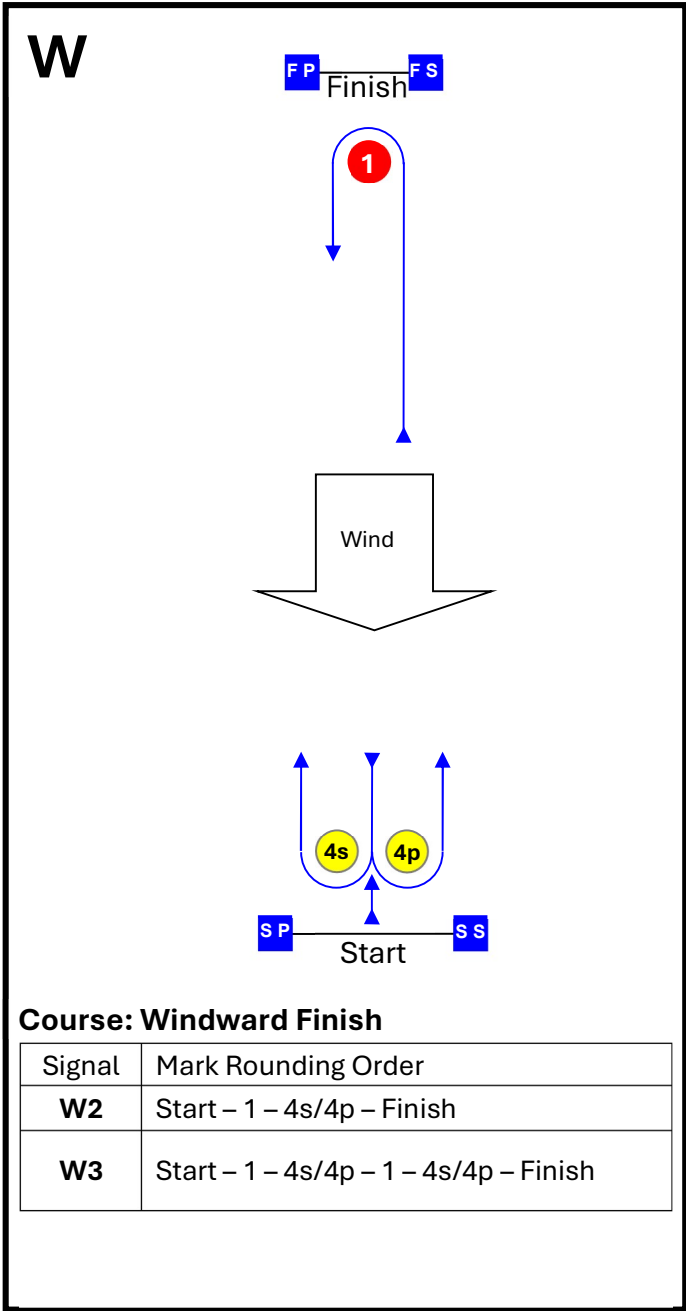

Mark	Description
1	Red YAMAHA cylinder buoy
4s 4p	Yellow cylinder buoys
SS Starting mark starboard end	Committee boat
SP Starting mark port end	Orange teardrop buoy with an ORANGE flag
FS Finishing mark starboard end	Committee boat
FP Finishing mark port end	Orange teardrop buoy with a BLUE flag
Replacement mark	Orange conical buoy